

# STYLE C1

## TREAD FOR STEEL STAIRS WITHOUT RISERS

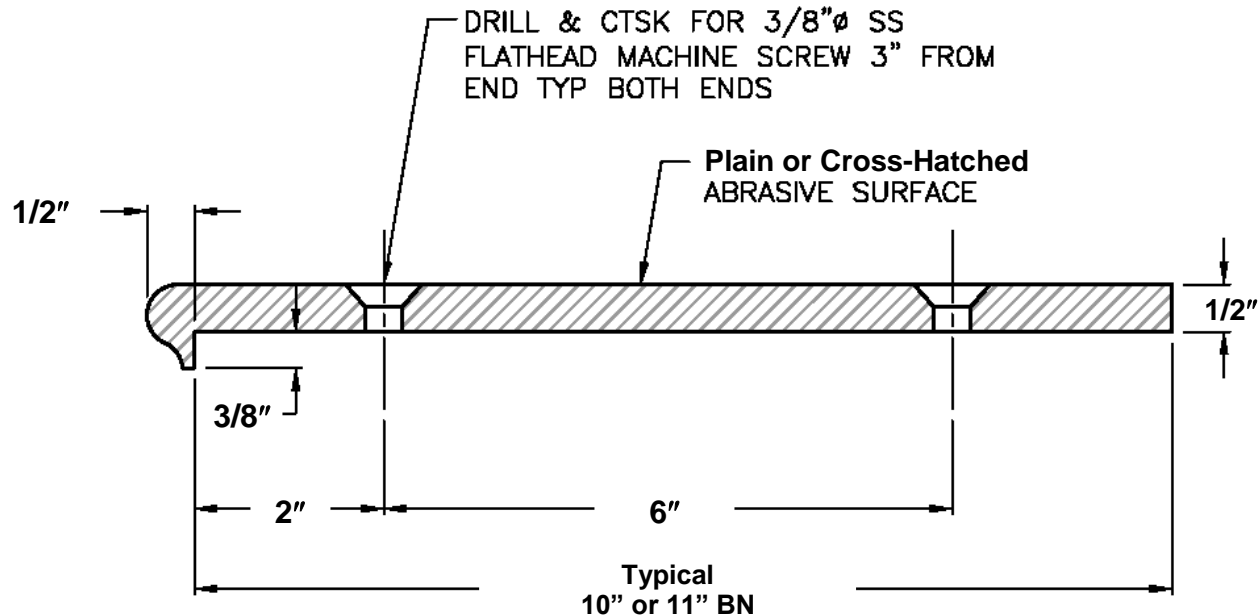

Custom Widths  
Also Available

DO NOT PRE DRILL STEEL  
USE TREAD AS TEMPLATE

**Available in Cast Abrasive Aluminum, Bronze, Nickel Bronze & Iron**

PLEASE NOTE: Dimensions and design must be field checked by others before fabrication. All material will be fabricated to dimensions shown on final approved drawings, field checked by others. Safe-T-Metal is not responsible for any dimensions, design errors, or quantities not shown on final field checked drawings.

Approved:	Project:	Holes:	Safe-T-Metal Products by Meloon Foundries LLC Phone: 800-886-7238 Fax: 315-454-3253 1841 LeMoyne Avenue Syracuse, NY 13208	Date:
	Customer:	Shop Paint:		Customer P.O. #:
Date:	Material:			Sheet No.: