

## STYLE B

### TREAD FOR STEEL STAIRS WITHOUT RISERS

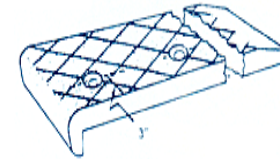

Can be provided with Square Back or With Beveled Back Edge as shown above.

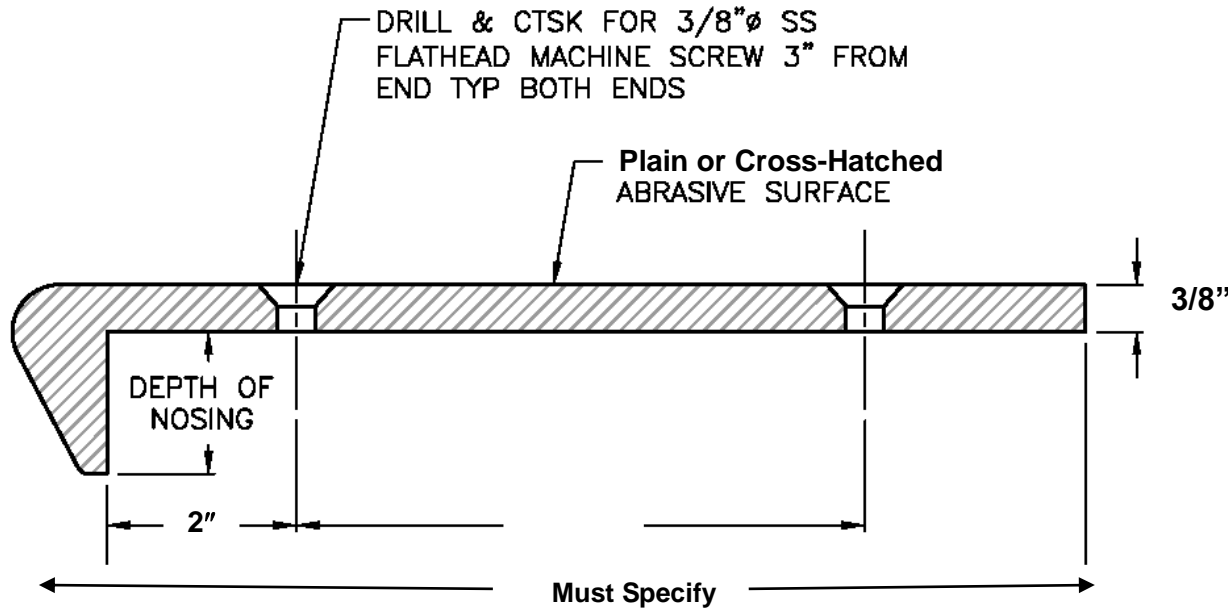

TYPICAL SIZES	
DEPTH OF NOSING, IN.	STYLE NO.
1/2	B2
3/4	B3
1	B4
1 1/2	B5

Also Available For Use As  
Stair Nosing; Furnished with Anchors.

**DO NOT PRE DRILL STEEL  
USE TREAD AS TEMPLATE**

**Available in Cast Abrasive Aluminum, Bronze, Nickel Bronze & Iron**

PLEASE NOTE: Dimensions and design must be field checked by others before fabrication. All material will be fabricated to dimensions shown on final approved drawings, field checked by others. Safe-T-Metal is not responsible for any dimensions, design errors, or quantities not shown on final field checked drawings.

Approved:	Project:	Holes:	Safe-T-Metal Products by Meloon Foundries LLC Phone: 800-886-7238 Fax: 315-454-3253 1841 LeMoyne Avenue Syracuse, NY 13208	Date:
	Customer:	Shop Paint:		Customer P.O. #:
Date:	Material:			Sheet No.: